



INSTALLATION INSTRUCTIONS

TJ Console Part #040

Please read and fill out the enclosed warranty registration card to activate your warranty.

SHIPMENT CONTENTS

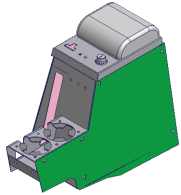

Console

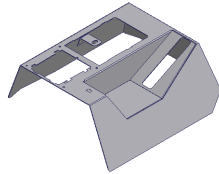

Front shift lever console

Shipping Package



(2) 1/4" Hole plugs

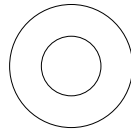

(4) 5/16" Washers

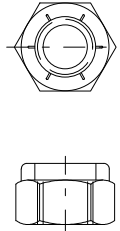

(2) 5/16 Locknuts

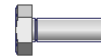

(4) 6-32x5/8 Screws

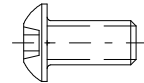

(2) 1/4-20 x 1/2 Screws



(3) 1/4 x 3/4" Self Tapping Screws



(1) 1/4 x 2 1/4" Self tapping screw



(2) 5/16-18 X 1 1/4" Bolts

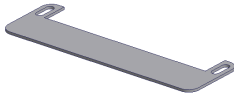

(1) Shift boot plate

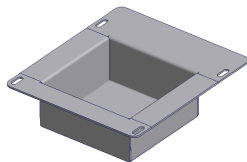

(1) Front console tray



(1) 6 Speed shifter bracket

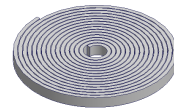

Neoprene seal

Tools Needed

- (1) 1/2" wrench or ratchet, socket, and extension
- (1) 1/2" wrench
- (1) 3/8" wrench or ratchet, socket, and extension
- (1) 1/4" Wrench
- Phillips head screwdriver, short
- 3/8" drill bit
- Electric drill
- Silicone sealant (not necessary but recommended)

Installation

1. Please read all instructions before starting installation.

NOTE: If you are installing this console in a 2001 or newer Jeep TJ (That came with the factory console with the sub-woofer cutout) this console may not completely cover the area on the floor where the carpet was cut at the rear of the console. An optional rear drink holder can be purchased separately and mounted after the console is installed to cover this area. The part number for this 9 Degree Rear Drink Holder is 070-(color code).

2. It is recommended to use silicone sealant on any mounting points to vehicle body to prevent future rust problems.
3. Removing one or both of the seats will make installation easier.
4. Apply the rubber seal to the underside of the lid. (SEE FIGURE 1)
5. If you do not have a factory console, remove the rubber emergency brake cover. Otherwise remove the (6) self-tapping screws from the factory console. Two are located inside the console (or, in 2001& up, under the rubber inside the rear drinkholder), two are on the passenger's side along the bottom, one is in the front cup holder, and one is under the gear shift boot (shift boot can be removed by gently pulling the plastic base up out of its mounting hole). Save these screws because you may reuse some of them.
6. In vehicles equipped with the air bag switch it can be removed without disconnecting wires. To do this push or pull the faceplate out of the original console and then maneuver it back through the opening it came out of. In 2003 TJ's the tray from the original console should be removed and reused.

Warning! Make sure that there is nothing under the vehicle that will be damaged by the drill bit when drilling.

7. Drill out the two original mounting holes (HOLES 1 AND 2 IN FIGURE 2), located on the floor of the vehicle, to 3/8" diameter (In 2001 and newer TJ's these holes (1 and 2) may not already be in the floor and will have to be drilled).
8. Install the Tuffy console by guiding the console over the emergency brake; be careful not to tear the seats.
9. Install the front shift lever console over the 4WD shifter. Moving the levers into different locations may make installation easier. Be sure emergency brake is on. Be careful not to rip the gearshift boot, tear the seats, or scratch the dash.
10. Attach the front shift lever console to the drink holder using (2) 1/4-20x1/2" Phillips pan head screws. (SEE FIGURE 4)
11. Line up all of the mounting holes.
12. Insert the (1) 1/4-20 x 3/4" screw in the bracket under the gearshift boot in the front shift lever console (HOLE 4 IN FIGURE 2). In 1997 – 2000 TJs - Insert (2) 1/4-20 x 3/4" screws in the passengers side of the console. (HOLES 5 AND 6 IN FIGURE 3)
13. Insert the 1/4-20 x 2 1/4" self-tapping screw in the mounting hole in the bottom of the drink holder (HOLE 3 IN FIGURE 2).
14. Bolt the console down using the (2) 5/16" bolts, (2) 5/16" nuts, and (4) 5/16" washers (IN HOLES 1 AND 2 IN FIGURE 2), push at least one bolt up from the bottom for added security.
15. Reinstall shift boot cover and plastic rectangular boot retainer from the factory console. If the vehicle has an automatic transmission the shift plate should be installed by pushing the ears on the plate through the corresponding slots in the console then sliding it toward the rear of the vehicle to hold it in place. To secure the shift boot do the following applicable steps.

If the vehicle is equipped with the air bag switch (In 2003 and up TJ's the tray from the original console should be used here)

16. The switch can be installed without disconnecting any wires. To do this, maneuver the air bag switch faceplate up from the bottom through the opening in the console then snap it into place.
17. Attach the shift boot plate to the console using (2) 6-32 x 5/8 screws (SEE FIGURE 5). Position the shift boot plate flush against shift boot so it holds the shift boot tightly.

If the vehicle is not equipped with the air bag switch

18. Attach the front console tray using (4) 6-32 x 5/8" screws (SEE FIGURE 6). Position the tray flush against the shift boot so it holds the shift boot tightly.

If the vehicle is equipped with a 6 speed manual transmission.

19. Place the front console tray in the cutout. Then sandwich the Original shift boot between the Front Console and the 6 Speed Shifter Bracket. Fasten everything down with (4) 6-32 x 5/8" screws (SEE FIGURE 7).

20. Check lock operation. The rubber seal will need to be compressed initially and will wear-in with time.

ATTENTION:

FREQUENT LUBRICATION IS NECESSARY ON THE LOCKING SYSTEM

The pushbutton lock contains an "O" ring seal to protect the interior from dust and water. If this mechanism is not lubricated regularly it will become difficult to operate and it may not return to its home position preventing the key from operating the lock. If this happens simply pull up on the pushbutton to manually bring it back to its home position. Lubricate the pushbutton with a light lubricant such as silicone spray. The pushbutton may have to be periodically disassembled and cleaned.

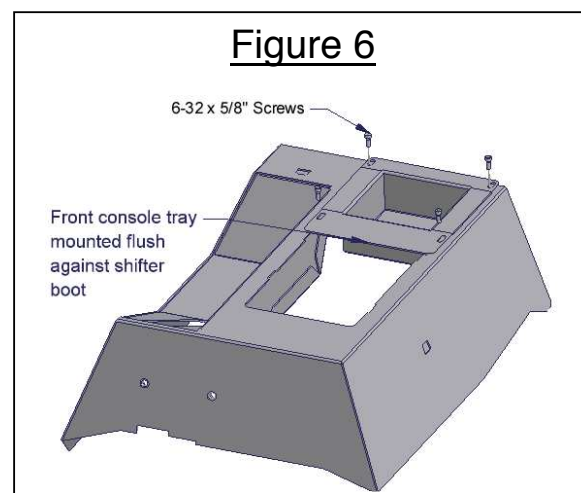
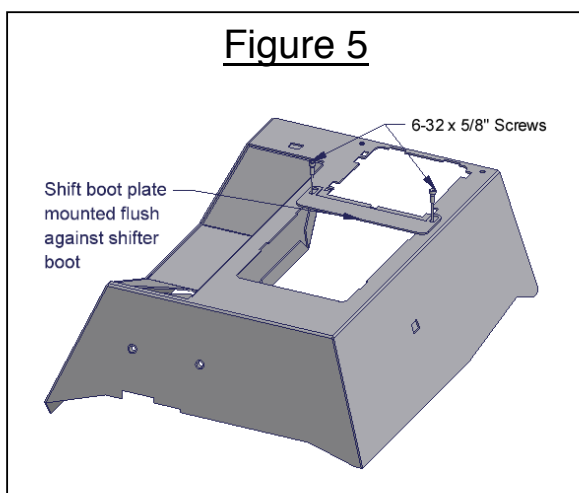
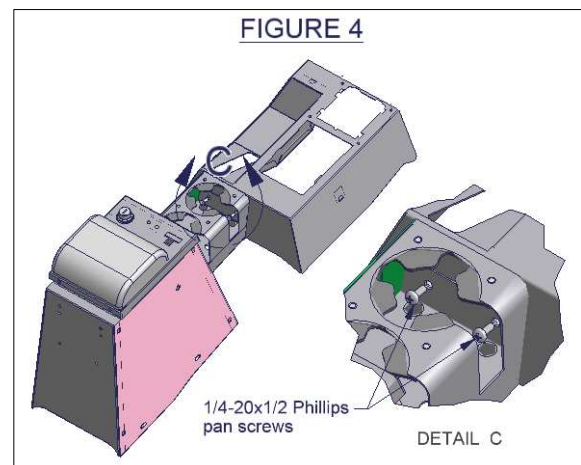
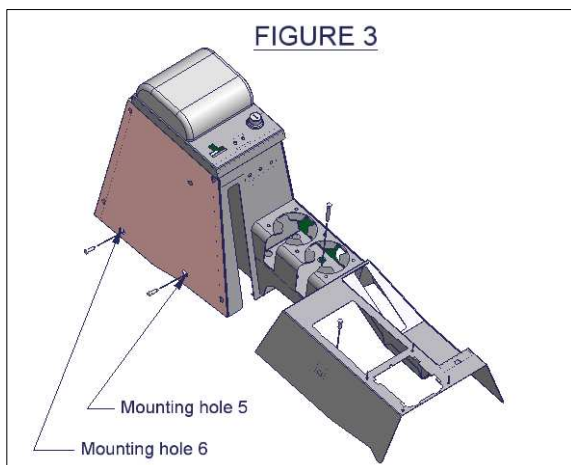
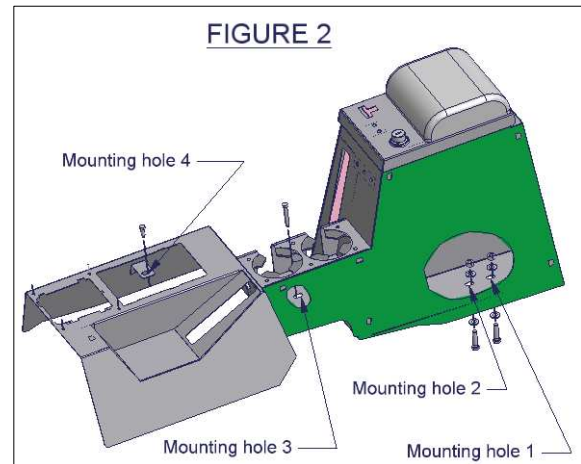
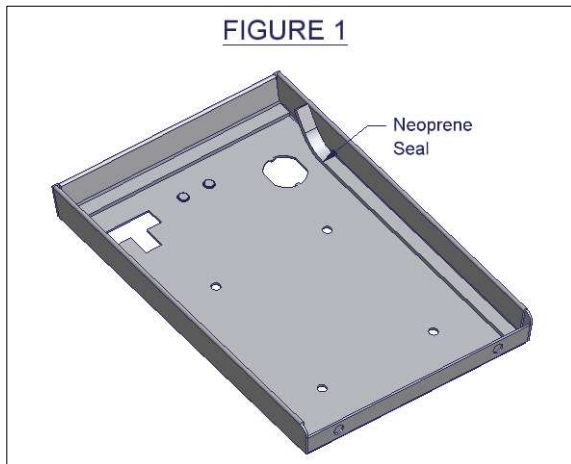
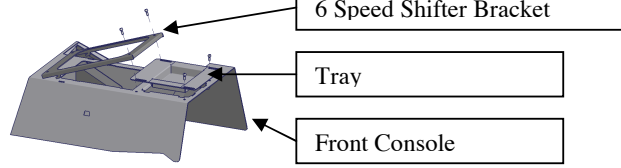

FIGURE 7



Call (970) 564-1762 for Technical Support